



Type: Wafer, Lugged
Face to Face: API609, BS EN 558, DIN3202, ISO 5752
Flange: DIN, BS, UNI, ISO, ANSI, AS, JIS
Mounting Flange: ISO5211

Working Pressure: PN10 (150PSI)
Application: Chemical/Petrochemical/Processing, Power and Utilities, Paper and Pulp, Food & Beverage, Pharmaceutical

Retaining System

The shaft is retained in the body with a retaining ring, a thrust washer and two C-rings, providing a "blow-out proof" shaft assembly. The retaining ring may be easily removed with a standard hand tool on field disassembly.

Shaft

One-piece through shaft ensures dependability and positive disc positioning.

Bushings (4-5)

Shaft bushings reduce torque and isolate the shaft from the valve body, preventing seizure of the shaft due to corrosion in the shaft journal.

PTFE Seat

EPDM with phenolic-backed seat provides resilient support for the molded PTFE, thus maximizing the shut-off and cycle life of seat.

Disc and Shaft Connection

The square connection eliminates shaft retention components being exposed to the line media. Maximum flow is achieved.

Mounting Flange

ISO 5211 mounting flange accommodates direct mounting of all types of actuators, including: handles, gear operators, electric and pneumatic.

O-Ring (1-2)

Shaft seal provides further assurance against shaft leakage.

Flats Seal

Smooth finished disc flats mate with seat flats to give a highly efficient primary seal that prevents leakage into the shaft area.

Two Piece Body

Two piece body allows for ease of assembly and maintenance.

Disc

Stainless steel or stainless steel PFA (min. thickness 0.1mm) coated disc prevents chemical corrosion from flow media. Precision profile provides bubble-tight shut-off, assures minimum torque and longer seat life.

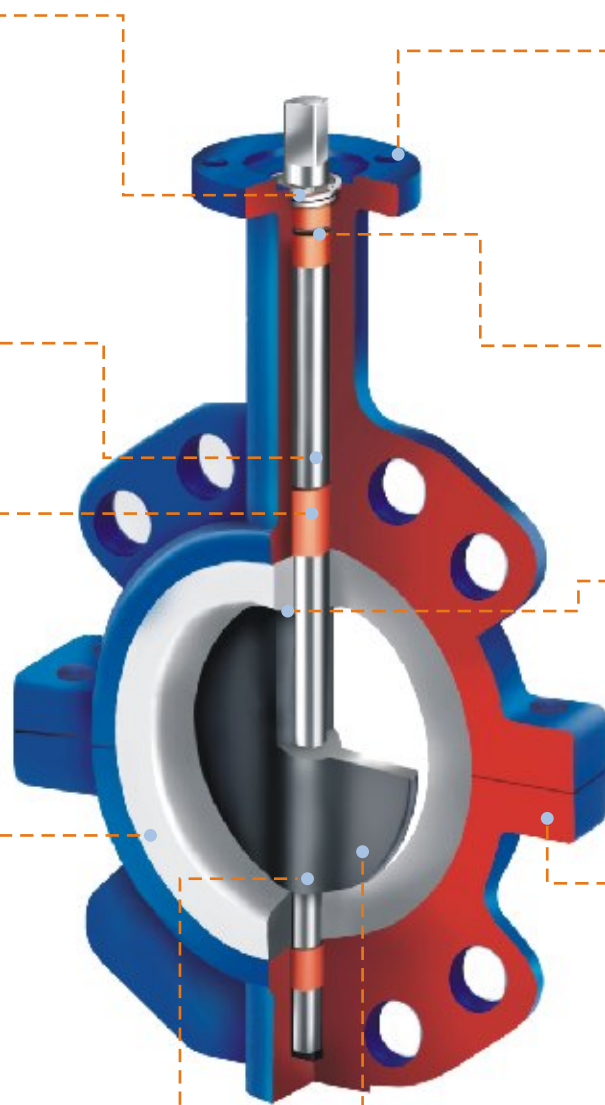

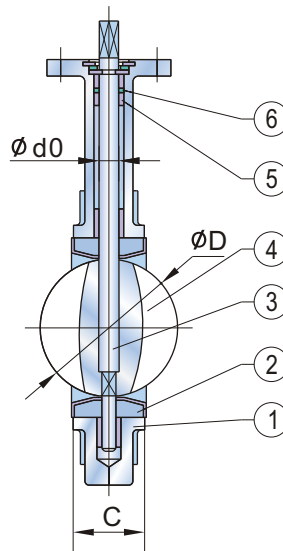
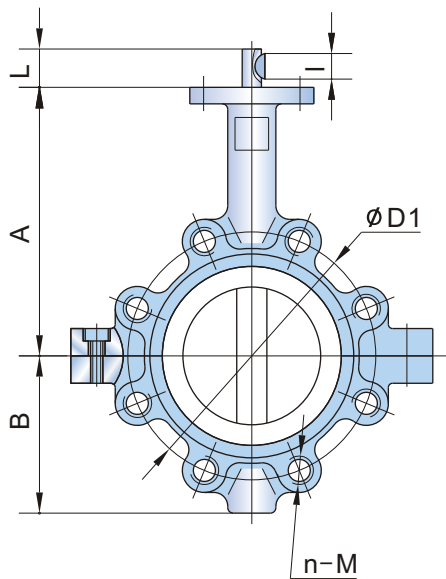
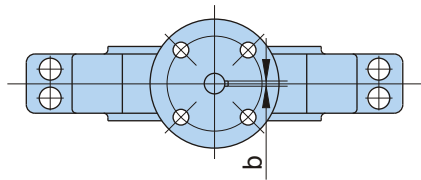
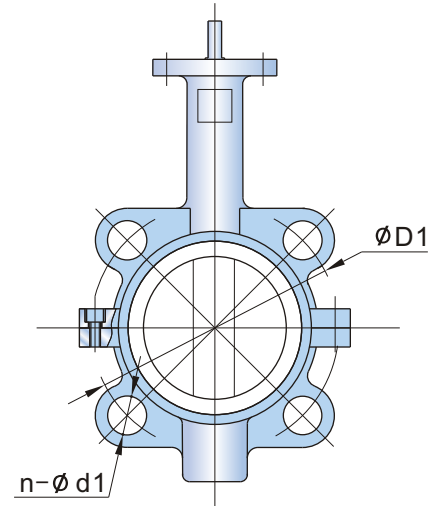
LUG TYPE
Series 400LWAFER TYPE
Series 400W

ROUND WITH KEY

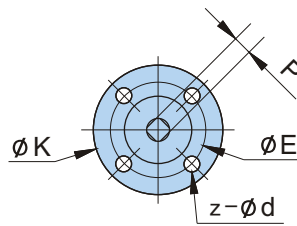

DIAGONAL SQUARE HEAD

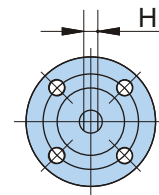

DOUBLE D HEAD

STANDARD MATERIALS OF MAIN PARTS

ITEM	PART NAME	MATERIAL
1	Body	Cast Iron, Ductile Iron
2	Seat	PTFE
3	Shaft	Stainless Steel 410, 316, 17-4PH
4	Disc	CF8M+PTFE(PFA), CF8M
5	Bushing	PTFE
6	O Ring	Viton

DIMENSIONS AND WEIGHTS

SIZE		A	B	C	D	L	d0	P	H	KEY bXI	UPPER FLANGE			ANSI 150			DIN PN10/16			Weight (kg)	
in	DN										K	E	z-d	D1	n-d1	M	D1	n-d1	M	Wafer	Lug
1-1/2	40	145	75	33	42.4	32	12.6	9	10	3X16	77	50	4-7	98.5	4-16	1/2"	110	4-18	M16	3.2	4.2
2	50	160	80	42	52.6	32	14.3	11	10	3X16	90	70	4-9	120.5	4-19	5/8"	125	4-18	M16	3.75	4.75
2-1/2	65	175	89	44.7	64.5	32	14.3	11	10	3X16	90	70	4-9	139.5	4-19	5/8"	145	4-18	M16	4.75	5.95
3	80	181	95	45.2	78.8	32	14.3	11	10	3X16	90	70	4-9	152.5	4-19	5/8"	160	4/8-18	M16	5	6.20
4	100	200	114	52.1	104	32	15.77	11	12	5X19	90	70	4-9	190.5	8-19	5/8"	180	8-18	M16	6.75	9.95
5	125	213	127	54.4	123.3	32	18.92	14	14	5X19	90	70	4-9	216	8-22	3/4"	210	8-18	M16	9.03	12.13
6	150	226	139	55.8	155.6	32	18.92	14	14	5X19	90	70	4-9	241.5	8-22	3/4"	240	8-23	M20	10.04	14.44
8	200	260	175	60.6	202.5	45	22.1	17	17	5X19	125	102	4-12	298.5	8-22	3/4"	295	8/12-23	M20	17.5	23
10	250	292	203	65.6	250.5	45	28.45	22	22	8X28	125	102	4-12	362	12-25	7/8"	350/355	12-23/27	M20/M24	25	33.70
12	300	337	242	76.9	301.6	45	31.6	22	24	8X28	140	102	4-12	432	12-25	7/8"	400/410	12-23/27	M20/M24	36	50.11
14	350	368	267	76.5	333.3	45	31.6	22	24	8X28	140	102	4-12	476	12-29	1"	460/470	16-23/27	M20/M24	47	67
16	400	400	309	86.5	389.6	51.2	33.15	24	24	10X50	197	140	4-18	540	16-29	1"	515/525	16-27/30	M24/M27	69	109

NOTE: The type of key for size 16" is flat.