



Type: Flanged
Face to Face: DIN3202, ISO 5752
Flange: DIN, BS, UNI, ISO, ANSI
Mounting Flange: ISO5211

Working Pressure: DN50 – 600: PN16 (200PSI)
DN700 and above: PN10 (150PSI)
Application: Water Supply & Sewage,
Chemical/Petrochemical/Processing,
Power and Utilities, Paper and Pulp

Shaft

One-piece through or two pieces shaft ensures dependability and positive disc positioning.

Mounting Flange

ISO5211 mounting flange accommodates direct mounting of all types of actuators, including: handles, gear operators, electric and pneumatic.

Taper Pin

Precision taper pin ensure positive, vibration proof, shaft to disc connection. Field replaceable.

Seat Face

Seat to flange seal eliminates the need for flange gaskets.

Seat

Rubber seat is vulcanized to body. Good integral support, stable and solid, stretch resistant, leakage proof.

Disc

Precision profile provides bubble-tight shut-off, assures minimum torque and longer seat life.



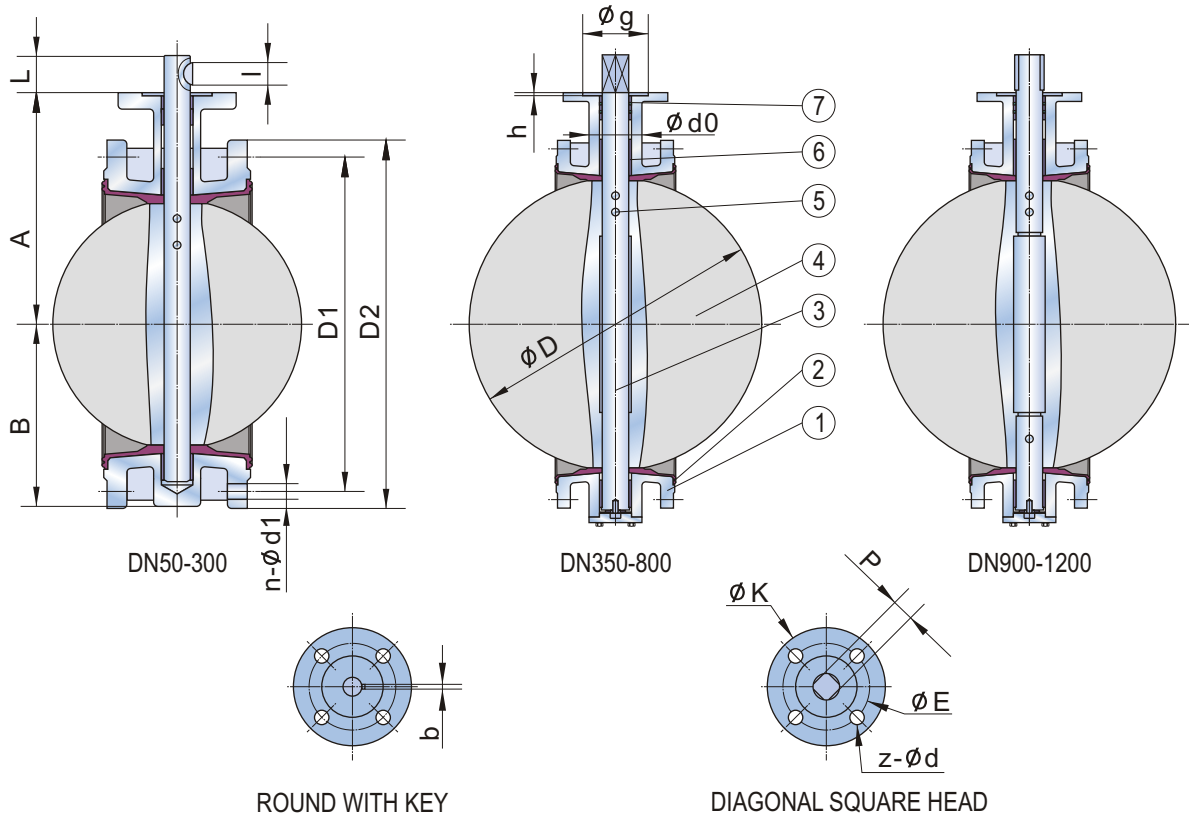

STANDARD MATERIALS OF MAIN PARTS

ITEM	PART NAME	MATERIAL
1	Body	Cast Iron, Ductile Iron
2	Seat	NBR, EPDM
3	Shaft	Stainless Steel 410, 431, 316, 17-4PH
4	Disc	Ductile Iron+Ni, CF8, CF8M, Bronze
5	Pin	Stainless Steel
6	Bushing	PTFE, Bronze
7	O Ring	NBR, EPDM

DIMENSIONS AND WEIGHTS

SIZE		A	B	C	D	L	d0	P	Key bxl	UPPER FLANGE					DIN PN10/16			Weight (kg)
in	DN									K	E	z-d	g	h	D2	D1	n-d1	
2	50	120	83	108	52.6	32	12.6	9	3X16	65	50	4-7	35	3.5	165	125	4-18	6.8
2-1/2	65	130	93	112	64.5	32	12.6	9	3X16	65	50	4-7	35	3.5	185	145	4-18	8.6
3	80	145	100	114	78.8	32	12.6	9	3X16	65	50	4-7	35	3.5	200	160	4/8-18	9.7
4	100	155	114	127	104	32	15.77	11	5X19	90	70	4-9	55	3.5	220	180	8-18	13.2
5	125	170	125	140	123.3	32	18.92	14	5X19	90	70	4-9	55	3.5	250	210	8-18	18.7
6	150	190	143	140	155.6	32	18.92	14	5X19	90	70	4-9	55	3.5	285	240	8-23	22.2
8	200	208	176	152	202.5	45	22.1	17	5X19	125	102	4-12	70	3.5	340	295	8/12-23	32.6
10	250	238	204	165	250.5	45	28.45	22	8X28	125	102	4-12	70	3.5	395/405	350/355	12-23/27	43.5
12	300	280	223	178	301.6	45	31.6	22	8X28	150	125	4-14	85	3.5	445/460	400/410	12-23/27	57.9
14	350	310	270	190	333.3	45	31.6	22	8X28	150	125	4-14	85	3.5	505/520	460/470	16-23/27	81.6
16	400	340	300	216	389.6	51.2	33.15	24	10X50	175	140	4-18	100	4.5	565/580	515/525	16-27/30	105.7
18	450	375	355	222	440.5	51.2	38	27	10X50	175	140	4-18	100	4.5	615/640	565/585	20-27/30	128
20	500	430	355	229	491.6	64.2	41.15	36	10X50	210	165	4-22	130	5.5	670/715	620/650	20-27/33	164.4
24	600	500	410	267	592.5	70.2	50.65	36	2-16X60	210	165	4-22	130	5.5	780/840	725/770	20-30/36	234.5
28	700	560	478	292	695	66	63.35	-	2-18X63	300	254	8-18	200	5.5	895/910	840	24-30/36	337.9
32	800	620	529	318	794.7	66	63.35	-	2-18X63	300	254	8-18	200	5.5	1015/1025	950	24-33/39	474.8
36	900	685	584	330	864.7	118	75	-	2-20X100	350	298	8-22	230	5.5	1115/1125	1050	28-33/39	594.8
40	1000	735	657	410	965	142	85	-	2-22X125	350	298	8-22	230	5.5	1230/1255	1160/1170	28-36/42	793.3
48	1200	917	799	470	1161.2	150	105	-	2-28X125	415	356	8-33	260	5.5	1455/1485	1380/1390	32-39/48	1290

NOTE: Fact to face C is in accordance with DIN 3202 F16 and equal to ISO 5752 13 series.