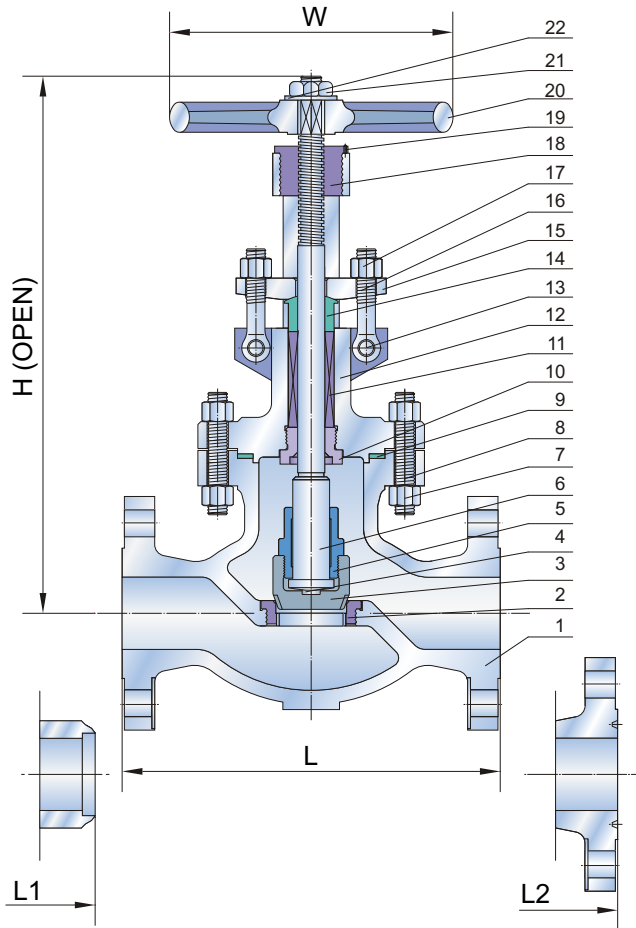



Figure No. GL1RCB8  
GL1BCB8  
GL1JCB8



### FEATURES

|  |
|--|
| OS & Y, Rising Stem                    |
| Bolted Bonnet                          |
| Conic Disc                             |
| Extended Bonnet for Cryogenic Services |
| Impact Handwheel Optional              |
| Gear Optional                          |

### SPECIFICATIONS

|              |                     |
|--------------|---------------------|
| Design       | ASME B16.34/BS 1873 |
| Face to Face | ASME B16.10         |
| End to End   | ASME B16.10         |
| End Flange   | ASME B16.5          |
| BW End       | ASME B16.25         |
| Test         | API 598             |
| Special      | NACE MR-01-75       |

### STANDARD MATERIALS OF PARTS

| ITEM | PART NAME         | MATERIAL                                    |
|------|-------------------|---|
| 1    | Body              | ASTM A216 GR.WCB                            |
| 2    | Seat Ring         | ASTM A105 + Stellite Faced                  |
| 3    | Disc              | ASTM A105 + 13Cr Faced                      |
| 4    | Disc Thrust Plate | ASTM A276 Type 420                          |
| 5    | Disc Nut          | ASTM A276 Type 410                          |
| 6    | Stem              | ASTM A182 GR.F6                             |
| 7    | Bonnet Bolt Nuts  | ASTM A194 GR.2H                             |
| 8    | Bonnet Bolts      | ASTM A193 GR.B7                             |
| 9    | Gasket            | Soft Iron+Graphite                          |
| 10   | Backseat Bushing  | ASTM A276 Type 410                          |
| 11   | Stem Packing      | Braided Graphite & Die formed Graphite Ring |
| 12   | Bonnet            | ASTM A216 GR.WCB                            |
| 13   | Eye Bolt Pins     | Carbon Steel                                |
| 14   | Gland             | ASTM A276 Type 410                          |
| 15   | Gland Flange      | ASTM A216 GR.WCB                            |
| 16   | Gland Eye Bolts   | ASTM A307 GR.B                              |
| 17   | Eye Bolt Nuts     | ASTM A194 GR.2H                             |
| 18   | Yoke Bush         | ASTM A439 GR.D-2                            |
| 19   | Screw             | Carbon Steel                                |
| 20   | Handwheel         | Ductile Iron                                |
| 21   | Handwheel Nut     | ASTM A194 GR.2H                             |
| 22   | Washer            | Carbon Steel                                |

Gear Standard for 16" & Larger

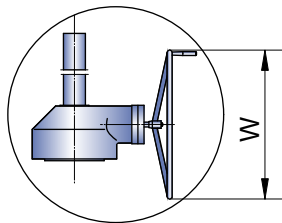

### Dimensions and Weights

| SIZE      | in | 2"    | 2.5"  | 3"    | 4"    | 6"    | 8"    | 10"   | 12"   | 14"   | 16"   | 18"   |
|-----------|----|-------|-------|-------|-------|-------|-------|-------|-------|-------|-------|-------|
|           | mm | 50    | 65    | 80    | 100   | 150   | 200   | 250   | 300   | 350   | 400   | 450   |
| L/L1      | in | 8.00  | 8.50  | 9.50  | 11.50 | 16.00 | 19.50 | 24.50 | 27.50 | 31.00 | 36.00 | 38.50 |
|           | mm | 203   | 216   | 241   | 292   | 406   | 495   | 622   | 698   | 787   | 914   | 978   |
| L2        | in | 8.50  | 9.00  | 10.00 | 12.00 | 16.50 | 20.00 | 25.00 | 28.00 | 31.50 | 36.50 | 39.00 |
|           | mm | 216   | 229   | 254   | 305   | 419   | 508   | 635   | 711   | 800   | 927   | 991   |
| H         | in | 13.58 | 16.34 | 15.94 | 19.09 | 20.47 | 23.62 | 30.00 | 33.94 | 38.58 | 47.05 | 51.18 |
|           | mm | 345   | 415   | 405   | 485   | 520   | 600   | 762   | 862   | 980   | 1195  | 1300  |
| W         | in | 8     | 8     | 10    | 12    | 14    | 18    | 20    | 25    | 25    | 24    | 24    |
|           | mm | 200   | 200   | 250   | 300   | 350   | 450   | 500   | 640   | 640   | 610   | 610   |
| Weight RF | kg | 22    | 32    | 38    | 62    | 104   | 159   | 308   | 539   | 610   | 880   | 1150  |



Figure No. GL3RCB8  
GL3BCB8  
GL3JCB8

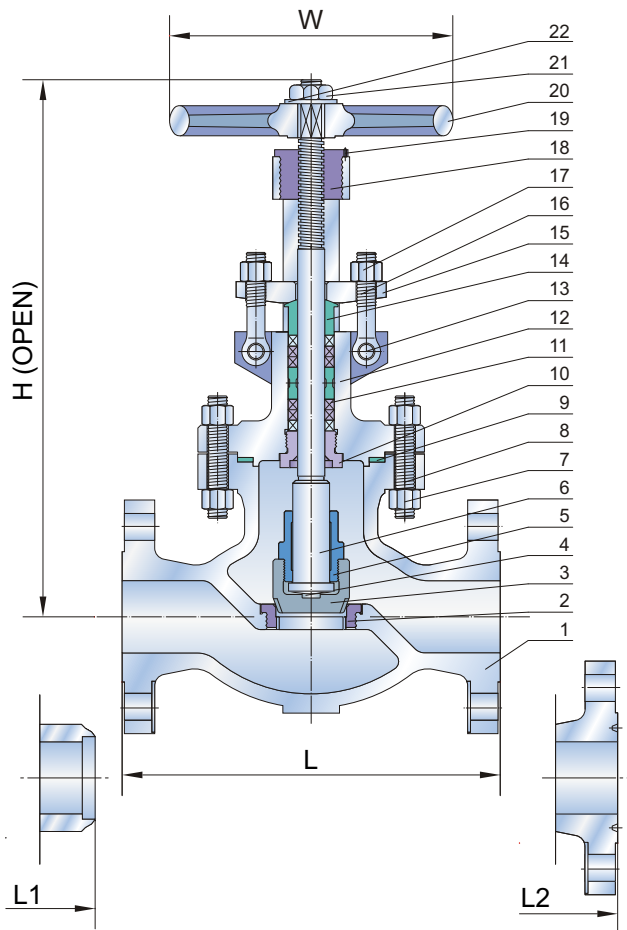

**FEATURES**

|  |
|--|
| OS & Y, Rising Stem                    |
| Bolted Bonnet                          |
| Conic Disc                             |
| Extended Bonnet for Cryogenic Services |
| Impact Handwheel Optional              |
| Gear Optional                          |

**SPECIFICATIONS**

|              |                     |
|--------------|---------------------|
| Design       | ASME B16.34/BS 1873 |
| Face to Face | ASME B16.10         |
| End to End   | ASME B16.10         |
| End Flange   | ASME B16.5          |
| BW End       | ASME B16.25         |
| Test         | API 598             |
| Special      | NACE MR-01-75       |

**STANDARD MATERIALS OF PARTS**

| ITEM | PART NAME               | MATERIAL                                    |
|------|-------------------------|---|
| 1    | Body                    | ASTM A216 GR.WCB                            |
| 2    | Seat Ring               | ASTM A105 + Stellite Faced                  |
| 3    | Disc                    | ASTM A105 + 13Cr Faced                      |
| 4    | Disc Thrust Plate       | ASTM A276 Type 420                          |
| 5    | Disc Nut                | ASTM A276 Type 410                          |
| 6    | Stem                    | ASTM A182 GR.F6                             |
| 7    | Bonnet Bolt Nuts        | ASTM A194 GR.2H                             |
| 8    | Bonnet Bolts            | ASTM A193 GR.B7                             |
| 9    | Gasket                  | Soft Iron+Graphite                          |
| 10   | Backseat Bushing        | ASTM A276 Type 410                          |
| 11   | Stem Packing            | Braided Graphite & Die formed Graphite Ring |
| 12   | Bonnet                  | ASTM A216 GR.WCB                            |
| 13   | Eye Bolt Pins           | Carbon Steel                                |
| 14   | Gland                   | ASTM A276 Type 410                          |
| 15   | Gland Flange            | ASTM A216 GR.WCB                            |
| 16   | Gland Eye Bolts         | ASTM A307 GR.B                              |
| 17   | Eye Bolt Nuts           | ASTM A194 GR.2H                             |
| 18   | Yoke Bush               | ASTM A439 GR.D-2                            |
| 19   | Screw                   | Carbon Steel                                |
| 20   | Handwheel               | Ductile Iron                                |
| 21   | Handwheel Nut           | ASTM A194 GR.2H                             |
| 22   | Washer                  | Carbon Steel                                |
| 23   | Lantern Ring On Request | ASTM A276 Type 410                          |

Lantern Ring On Request

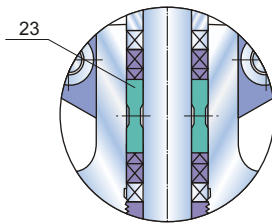

Gear Standard for 14" & Larger

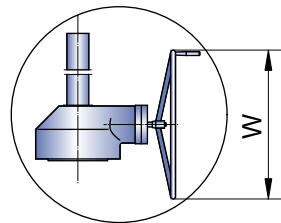

| Dimensions and Weights |    |       |       |       |       |       |       |       |       |       |
|------------------------|----|-------|-------|-------|-------|-------|-------|-------|-------|-------|
| SIZE                   | in | 2"    | 2.5"  | 3"    | 4"    | 6"    | 8"    | 10"   | 12"   | 14"   |
| L/L1                   | in | 10.50 | 11.50 | 12.50 | 14.00 | 17.50 | 22.00 | 24.50 | 28.00 | 33.00 |
|                        | mm | 267   | 292   | 318   | 356   | 445   | 559   | 622   | 711   | 838   |
| L2                     | in | 11.12 | 12.12 | 13.12 | 14.62 | 18.12 | 22.62 | 25.12 | 28.62 | 33.62 |
|                        | mm | 283   | 308   | 333   | 371   | 460   | 575   | 638   | 727   | 854   |
| H                      | in | 14.57 | 18.66 | 17.32 | 20.67 | 24.41 | 35.83 | 37.36 | 40.63 | 42.91 |
|                        | mm | 370   | 474   | 440   | 525   | 620   | 910   | 949   | 1032  | 1090  |
| W                      | in | 8     | 10    | 10    | 14    | 18    | 22    | 24    | 25    | 24    |
|                        | mm | 200   | 250   | 250   | 350   | 450   | 560   | 600   | 640   | 610   |
| Weight RF              | kg | 28    | 48    | 56    | 82    | 154   | 240   | 319   | 632   | 975   |



Figure No. GL6RCB8  
GL6BCB8  
GL6JCB8

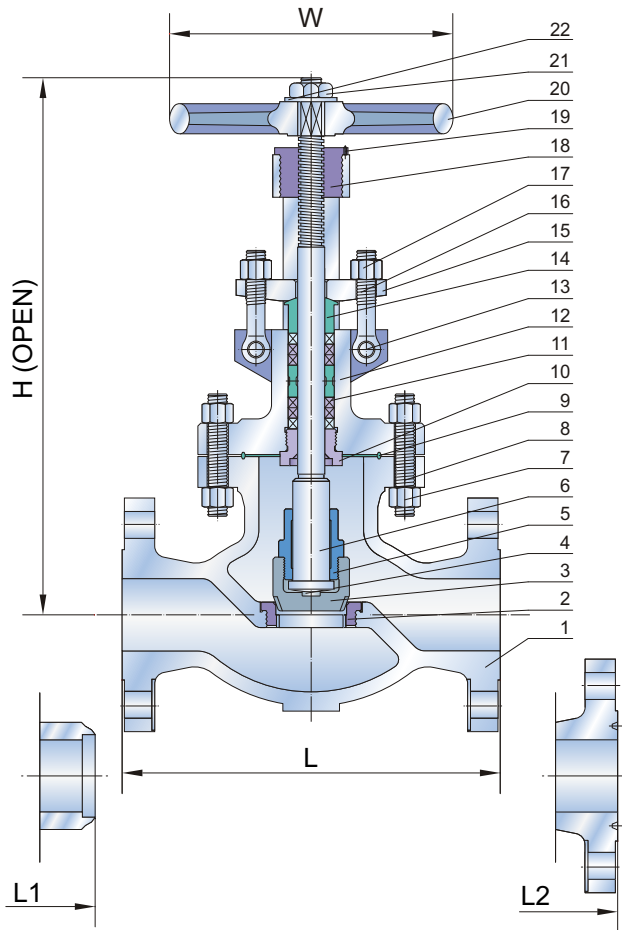

### FEATURES

|  |
|--|
| OS & Y, Rising Stem                    |
| Bolted Bonnet                          |
| Conic Disc                             |
| Extended Bonnet for Cryogenic Services |
| Impact Handwheel Optional              |
| Gear Optional                          |

### SPECIFICATIONS

|              |                     |
|--------------|---------------------|
| Design       | ASME B16.34/BS 1873 |
| Face to Face | ASME B16.10         |
| End to End   | ASME B16.10         |
| End Flange   | ASME B16.5          |
| BW End       | ASME B16.25         |
| Test         | API 598             |
| Special      | NACE MR-01-75       |

### STANDARD MATERIALS OF PARTS

| ITEM | PART NAME               | MATERIAL                                    |
|------|-------------------------|---|
| 1    | Body                    | ASTM A216 GR.WCB                            |
| 2    | Seat Ring               | ASTM A105 + Stellite Faced                  |
| 3    | Disc                    | ASTM A105 + 13Cr Faced                      |
| 4    | Disc Thrust Plate       | ASTM A276 Type 420                          |
| 5    | Disc Nut                | ASTM A276 Type 410                          |
| 6    | Stem                    | ASTM A182 GR.F6                             |
| 7    | Bonnet Bolt Nuts        | ASTM A194 GR.2H                             |
| 8    | Bonnet Bolts            | ASTM A193 GR.B7                             |
| 9    | Gasket, Ring Joint      | Soft Iron                                   |
| 10   | Backseat Bushing        | ASTM A276 Type 410                          |
| 11   | Stem Packing            | Braided Graphite & Die formed Graphite Ring |
| 12   | Bonnet                  | ASTM A216 GR.WCB                            |
| 13   | Eye Bolt Pins           | Carbon Steel                                |
| 14   | Gland                   | ASTM A276 Type 410                          |
| 15   | Gland Flange            | ASTM A216 GR.WCB                            |
| 16   | Gland Eye Bolts         | ASTM A307 GR.B                              |
| 17   | Eye Bolt Nuts           | ASTM A194 GR.2H                             |
| 18   | Yoke Bush               | ASTM A439 GR.D-2                            |
| 19   | Screw                   | Carbon Steel                                |
| 20   | Handwheel               | Ductile Iron                                |
| 21   | Handwheel Nut           | ASTM A194 GR.2H                             |
| 22   | Washer                  | Carbon Steel                                |
| 23   | Lantern Ring On Request | ASTM A276 Type 410                          |

Lantern Ring  
On Request

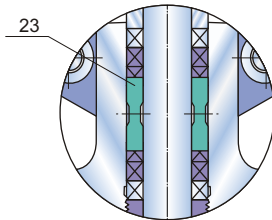

Gear Standard  
for 10" & Larger

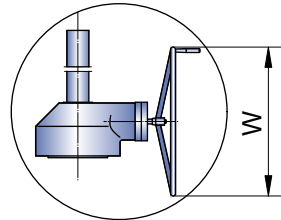

### Dimensions and Weights

| SIZE      | in | 2"    | 2.5"  | 3"    | 4"    | 6"    | 8"    | 10"   | 12"   |
|-----------|----|-------|-------|-------|-------|-------|-------|-------|-------|
|           | mm | 50    | 65    | 80    | 100   | 150   | 200   | 250   | 300   |
| L/L1      | in | 11.50 | 13.00 | 14.00 | 17.00 | 22.00 | 26.00 | 31.00 | 33.00 |
|           | mm | 292   | 330   | 356   | 432   | 559   | 660   | 787   | 838   |
| L2        | in | 11.62 | 13.12 | 14.12 | 17.12 | 22.12 | 26.12 | 31.12 | 33.12 |
|           | mm | 295   | 333   | 359   | 435   | 562   | 663   | 790   | 841   |
| H         | in | 18.19 | 21.26 | 23.03 | 26.38 | 34.88 | 36.69 | 40.94 | 50.39 |
|           | mm | 462   | 540   | 585   | 670   | 886   | 932   | 1040  | 1280  |
| W         | in | 10    | 10    | 12    | 18    | 20    | 25    | 24    | 24    |
|           | mm | 250   | 250   | 350   | 450   | 500   | 640   | 610   | 610   |
| Weight RF | kg | 36    | 70    | 85    | 123   | 404   | 450   | 700   | 900   |



Figure No. GL9RCB5 GL15RCB5 GL25RCB5  
 GL9BCB5 GL15BCB5 GL25BCB5  
 GL9JCB5 GL15JCB5 GL25JCB5

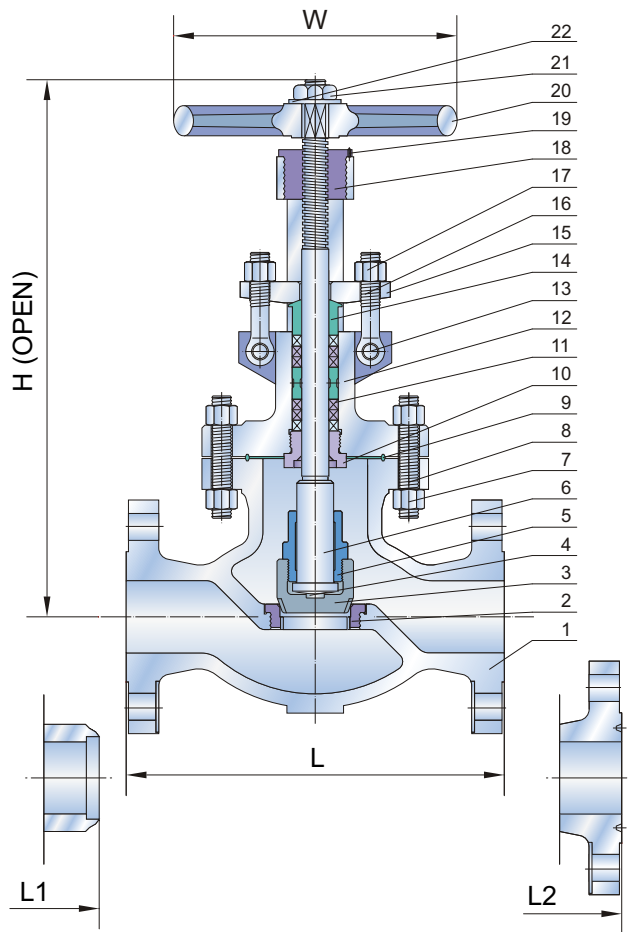

**FEATURES**

|  |
|--|
| OS & Y, Rising Stem                    |
| Bolted Bonnet                          |
| Conic Disc                             |
| Extended Bonnet for Cryogenic Services |
| Impact Handwheel Optional              |
| Gear Optional                          |

**SPECIFICATIONS**

|              |                     |
|--------------|---------------------|
| Design       | ASME B16.34/BS 1873 |
| Face to Face | ASME B16.10         |
| End to End   | ASME B16.10         |
| End Flange   | ASME B16.5          |
| BW End       | ASME B16.25         |
| Test         | API 598             |
| Special      | NACE MR-01-75       |

**STANDARD MATERIALS OF PARTS**

| ITEM | PART NAME               | MATERIAL                                    |
|------|-------------------------|---|
| 1    | Body                    | ASTM A216 GR.WCB                            |
| 2    | Seat Ring               | ASTM A105 + Stellite Faced                  |
| 3    | Disc                    | ASTM A105 + Stellite Faced                  |
| 4    | Disc Thrust Plate       | ASTM A276 Type 420                          |
| 5    | Disc Nut                | ASTM A276 Type 410                          |
| 6    | Stem                    | ASTM A182 GR.F6                             |
| 7    | Bonnet Bolt Nuts        | ASTM A194 GR.2H                             |
| 8    | Bonnet Bolts            | ASTM A193 GR.B7                             |
| 9    | Gasket, Ring Joint      | Soft Iron                                   |
| 10   | Backseat Bushing        | ASTM A276 Type 410                          |
| 11   | Stem Packing            | Braided Graphite & Die formed Graphite Ring |
| 12   | Bonnet                  | ASTM A216 GR.WCB                            |
| 13   | Eye Bolt Pins           | Carbon Steel                                |
| 14   | Gland                   | ASTM A276 Type 410                          |
| 15   | Gland Flange            | ASTM A216 GR.WCB                            |
| 16   | Gland Eye Bolts         | ASTM A307 GR.B                              |
| 17   | Eye Bolt Nuts           | ASTM A194 GR.2H                             |
| 18   | Yoke Bush               | ASTM A439 GR.D-2                            |
| 19   | Screw                   | Carbon Steel                                |
| 20   | Handwheel               | Ductile Iron                                |
| 21   | Handwheel Nut           | ASTM A194 GR.2H                             |
| 22   | Washer                  | Carbon Steel                                |
| 23   | Lantern Ring On Request | ASTM A276 Type 410                          |

Lantern Ring On Request

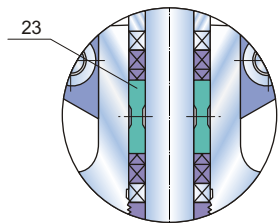

Gear Standard for 6" & Larger

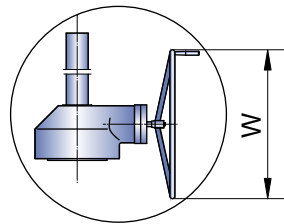

| Dimensions and Weights |    |       |       |       |       |       | CLASS 900 |  |  |
|------------------------|----|-------|-------|-------|-------|-------|-----------|--|--|
| SIZE                   | in | 2"    | 2.5"  | 3"    | 4"    | 6"    | 8"        |  |  |
| L/L1                   | in | 14.50 | 16.50 | 15.00 | 18.00 | 24.00 | 29.00     |  |  |
|                        | mm | 368   | 419   | 381   | 457   | 610   | 737       |  |  |
| L2                     | in | 14.62 | 16.62 | 15.12 | 18.12 | 24.12 | 29.12     |  |  |
|                        | mm | 371   | 422   | 384   | 460   | 613   | 740       |  |  |
| H                      | in | 23.62 | 25.98 | 26.18 | 31.50 | 43.62 | 46.61     |  |  |
|                        | mm | 600   | 660   | 665   | 800   | 1108  | 1184      |  |  |
| W                      | in | 14    | 14    | 18    | 20    | 24    | 24        |  |  |
|                        | mm | 350   | 350   | 450   | 500   | 610   | 610       |  |  |
| Weight RF              | kg | 95    | 138   | 122   | 195   | 435   | 730       |  |  |

| Dimensions and Weights |    |       |       |       |       |       | CLASS 2500 |  |  |
|------------------------|----|-------|-------|-------|-------|-------|------------|--|--|
| SIZE                   | in | 2"    | 2.5"  | 3"    | 4"    | 6"    | 8"         |  |  |
| L/L1                   | in | 17.75 | 20.00 | 22.75 | 26.50 | 36.00 | 40.25      |  |  |
|                        | mm | 451   | 508   | 578   | 673   | 914   | 1022       |  |  |
| L2                     | in | 17.87 | 20.25 | 23.00 | 26.88 | 36.50 | 40.87      |  |  |
|                        | mm | 454   | 514   | 584   | 683   | 927   | 1038       |  |  |
| H                      | in | 28.35 | 31.50 | 34.84 | 49.61 | 75.00 | 97.05      |  |  |
|                        | mm | 720   | 800   | 885   | 1260  | 1905  | 2465       |  |  |
| W                      | in | 16    | 20    | 22    | 24    | 24    | 24         |  |  |
|                        | mm | 400   | 500   | 560   | 600   | 610   | 610        |  |  |
| Weight RF              | kg | 176   | 264   | 308   | 759   | 1990  | 4390       |  |  |

| Dimensions and Weights |    |       |       |       |       |       | CLASS 1500 |  |  |
|------------------------|----|-------|-------|-------|-------|-------|------------|--|--|
| SIZE                   | in | 2"    | 2.5"  | 3"    | 4"    | 6"    | 8"         |  |  |
| L/L1                   | in | 14.50 | 16.50 | 18.50 | 21.50 | 27.75 | 32.75      |  |  |
|                        | mm | 368   | 419   | 470   | 546   | 705   | 832        |  |  |
| L2                     | in | 14.62 | 16.62 | 18.62 | 21.62 | 28.00 | 33.13      |  |  |
|                        | mm | 371   | 422   | 473   | 549   | 711   | 841        |  |  |
| H                      | in | 25.98 | 25.98 | 30.31 | 33.46 | 45.08 | 52.95      |  |  |
|                        | mm | 660   | 660   | 770   | 850   | 1145  | 1345       |  |  |
| W                      | in | 14    | 14    | 20    | 22    | 24    | 24         |  |  |
|                        | mm | 350   | 350   | 500   | 560   | 610   | 610        |  |  |
| Weight RF              | kg | 95    | 138   | 250   | 435   | 540   | 970        |  |  |